

# Tapered Flanged Well Assemblies

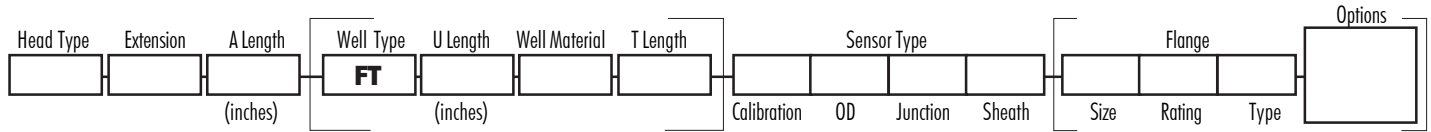

**To order:** To specify a complete assembly, indicate the code letter or value for each requirement. To order a well only, fill in only the boxes in brackets. Add a nipple or nipple-union-nipple to a well by including the extension code and "A" length in addition to the well codes.



## HEAD TYPE

0 No Head	FTA Flip Top Aluminum
CA Cast Aluminum	FTP Flip Top Poly (white)
CI Cast Iron	EPA Explosion Proof Aluminum
CSS Cast Stainless Steel	EPS Explosion Proof Stainless Steel
LCA Large Cast Aluminum	EHA Explosion Proof Aluminum
PP Polypropylene (Black)	EHI Explosion Proof Iron
PPS Polypropylene Sanitary	

Add X to the end of the order code of metallic heads, (i.e. EHAX), to add a corrosion resistant epoxy coating to meet NEMA 4X rating.  
For detailed description and ordering of heads see pages A-5 and A-6.

## EXTENSION

N Nipple Galvanized
NUN Nipple/Union/Nipple Galvanized
NS Nipple Stainless Steel
NUNS Nipple/Union/Nipple Stainless Steel
PNUN Pressure Seal in Union Galvanized
PNUNS Pressure Seal in Union Stainless Steel

See page A-7 for additional information.

## THERMOWELL - TYPE FT

Well Materials – For other materials, see page B-6.

A Alloy 600	M Monel® 400
AA Alloy 20	N Nickel
B Hastelloy® B	P 304SS
C Hastelloy® C	Q 310SS
D 321SS	R 316SS
F 347SS	S Carbon Steel
H 446SS	T Teflon®
I Alloy 800	V Alloy 825
LP Low Carbon 304SS	W Alloy 601
LR Low Carbon 316SS	Y Brass

### Flange Size

1" *
1 1/2"
2"
3"
4"

### Flange Rating

150	600
200	900
300	1500
400	

### Flange Type

RF	Raised Face
FF	Flat Face
RTJ	Ring Type Joint

\*Major OD is 7/8" for flange sizes 1" and smaller.

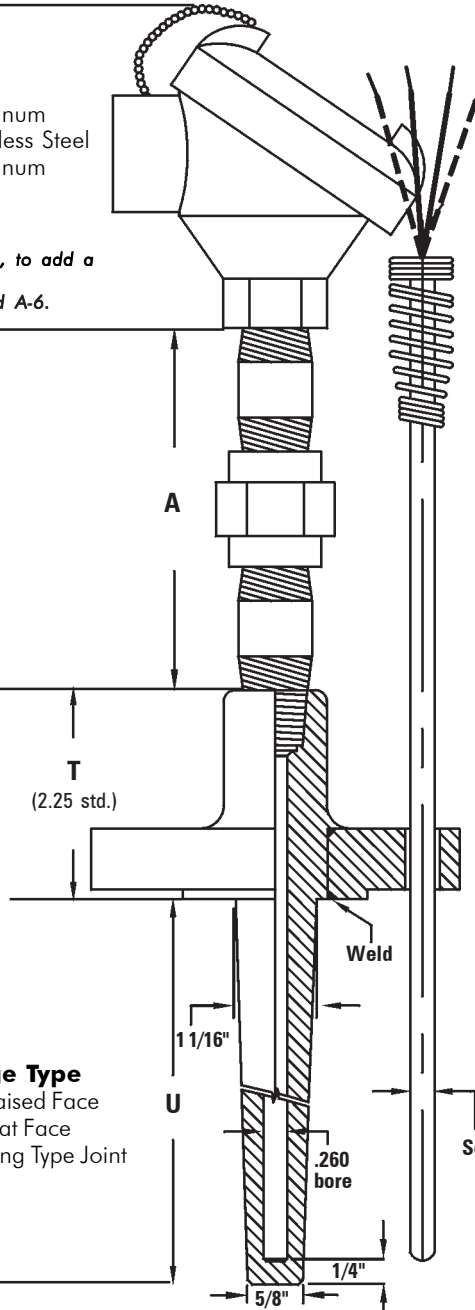

## SENSOR TYPE

### Sensor Calibration

J	Iron Constantan®
K	Chromel® Alumel®
T	Copper Constantan®
E	Chromel® Constantan®
N	Nicrosil® Nilil®
PO	Low Temp RTD to 500° F
PH	High Temp RTD to 900° F
PM	Heavy Duty RTD to 1100° F

Standard RTD is a three-wire 100 ohm Platinum / .00385 Alpha. For special limits on thermocouples, repeat calibration code, i.e. JJ. For Smart Stuff sensors use S prefix in front of calibration code.

### Sensor OD

316	3/16"
14	1/4"
516	5/16"
38	3/8"

### Sensor Junction

G	Grounded
U	Ungrounded
E	Exposed
DG	Dual Grounded
DU	Dual Ungrounded
DE	Dual Exposed
S	Single RTD
D	Dual RTD

### Sensor Sheath Materials

P	304SS
R	316SS
Q	310SS
A	Alloy 600

Standard Sheath Material is 316SS.

## OPTIONS

### Sensor Options

S	Smart Stuff
GA	Grade A RTD
TW	Two Wire RTD
FW	Four Wire RTD
HV	High Vibration RTD (PM only)
CR	Cryogenic RTD (PM only)
CT	Compensated Terminals (EHA/EHI head only)

### Thermowell Options

AO	Alumina Oxide Coating
FP	Full Penetration Weld
HT	Hydrostatic Testing to 10,000 psi
NC	NACE Certification for Well
OC	Oxygen Cleaned
ST	Stellite® Coating
TF	Teflon® Coating
TS	Tantalum Sheath

VC	Velocity Calculations
BC	Brass Plug and Chain
SC	SS Plug and Chain
WB	.385 Bore

If other than .385 Bore is required, specify bore size.

### Transmitter/Indicator Options

LCR	Fixed Range Type, RTD, FM
LCS	Programmable, Non FM
PT	Programmable FM
HC	Hart® Compatible

Provide Range and Temp F/C  
See pages A-33 – A36 for additional transmitter information.  
TI Temperature Indicator (use with transmitter)