

Tapered Threaded Well Assemblies

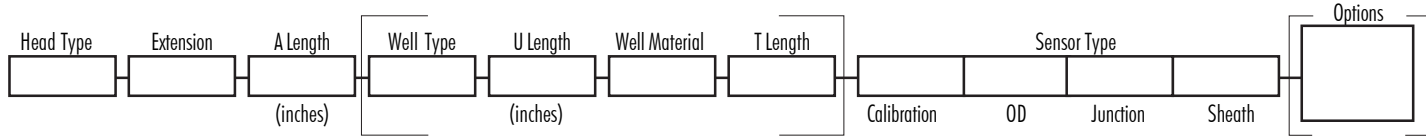

To order: To specify a complete assembly, indicate the code letter or value for each requirement. To order a well only, fill in only the boxes in brackets. Add a nipple or nipple-union-nipple to a well by including the extension code and "A" length in addition to the well codes.



HEAD TYPE

0	No Head	FTA	Flip Top Aluminum
CA	Cast Aluminum	FTP	Flip Top Poly (white)
CI	Cast Iron	EPA	Explosion Proof Aluminum
CSS	Cast Stainless Steel	EPS	Explosion Proof Stainless Steel
LCA	Large Cast Aluminum	EHA	Explosion Proof Aluminum
PP	Polypropylene (Black)	EHI	Explosion Proof Iron
PPS	Polypropylene Sanitary		

Add X to the end of the order code of metallic heads, (i.e. EHAX), to add a corrosion resistant epoxy coating to meet NEMA 4X rating. For detailed description and ordering of heads see pages A-5 and A-6.

EXTENSION

N	Nipple Galvanized
NUN	Nipple/Union/Nipple Galvanized
NS	Nipple Stainless Steel
NUNS	Nipple/Union/Nipple Stainless Steel
PNUN	Pressure Seal in Union Galvanized
PNUNS	Pressure Seal in Union Stainless Steel

See page A-7 for additional information.

THERMOWELL

Well Type

Type	Process NPT	OD1	OD2
ST	1/2"	.680	5/8"
ST0	3/4"	7/8"	5/8"
ST1	1"	1 1/16"	5/8"
ST2	1 1/4"	1 3/8"	7/8"
ST3	1 1/2"	1 5/8"	1 1/8"

Well Materials - For other materials, see page B-6.

A	Alloy 600	LP	Low Carbon 304SS	T	Teflon®
AA	Alloy 20	LR	Low Carbon 316SS	V	Alloy 825
B	Hastelloy® B	M	Monel® 400	W	Alloy 601
C	Hastelloy® C	N	Nickel	Y	Brass
D	321SS	P	304SS		
F	347SS	Q	310SS		
H	446SS	R	316SS		
I	Alloy 800	S	Carbon Steel		

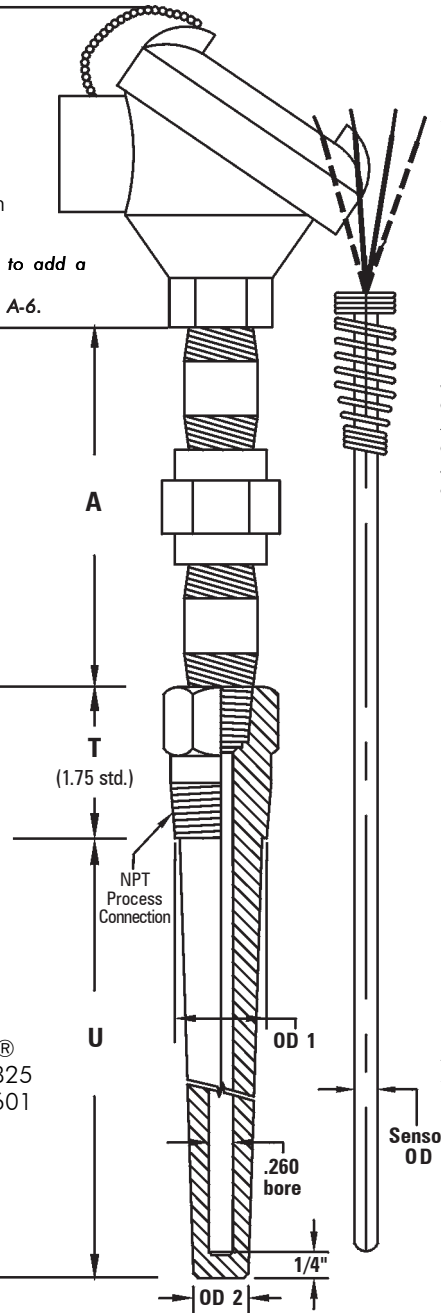

SENSOR TYPE

Sensor Calibration

J	Iron Constantan®
K	Chromel® Alumel®
T	Copper Constantan®
E	Chromel® Constantan®
N	Nicrosil® Nisil®
PO	Low Temp RTD to 500° F
PH	High Temp RTD to 900° F
PM	Heavy Duty RTD to 1100° F

Standard RTD is a three-wire 100 ohm Platinum / .00385 Alpha. For special limits on thermocouples, repeat calibration code, i.e. JJ. For Smart Stuff sensors use S prefix in front of calibration code.

Sensor OD

316	3/16"
14	1/4"
516	5/16"
38	3/8"

Sensor Junction

G	Grounded
U	Ungrounded
E	Exposed
DG	Dual Grounded
DU	Dual Ungrounded
DE	Dual Exposed
S	Single RTD
D	Dual RTD

Sensor Sheath Materials

P	304SS
R	316SS
Q	310SS
A	Alloy 600

Standard Sheath Material is 316SS.

OPTIONS

Sensor Options

S	Smart Stuff
GA	Grade A RTD
TW	Two Wire RTD
FW	Four Wire RTD
HV	High Vibration RTD (PM only)
CR	Cryogenic RTD (PM only)
CT	Compensated Terminals (EHA/EHI head only)

Thermowell Options

AO	Alumina Oxide Coating	TF	Teflon® Coating
HT	Hydrostatic Testing to 10,000 psi	VC	Velocity Calculations
NC	NACE Certification for Well	WB	.385 Bore
OC	Oxygen Cleaned	BC	Brass Plug and Chain
ST	Stellite® Coating	SC	SS Plug and Chain

If other than .385 Bore is required, specify bore size.

Transmitter/Indicator Options

LCR	Fixed Range Type, RTD, FM
LCS	Programmable, Non FM
PT	Programmable FM
HC	Hart® Compatible
Provide Range and Temp F/C	
See pages A-33 - A36 for additional transmitter information.	
TI	Temperature Indicator (use with transmitter)